

100 Roebuck road

Sean O'Donoghue
sean@bespoke.ie
+353 (87) 2630047



Statistics

Area: 99 m²
Living area: 121 m²
2 Floors
4 Bedrooms
1 Bathroom

Ground Floor

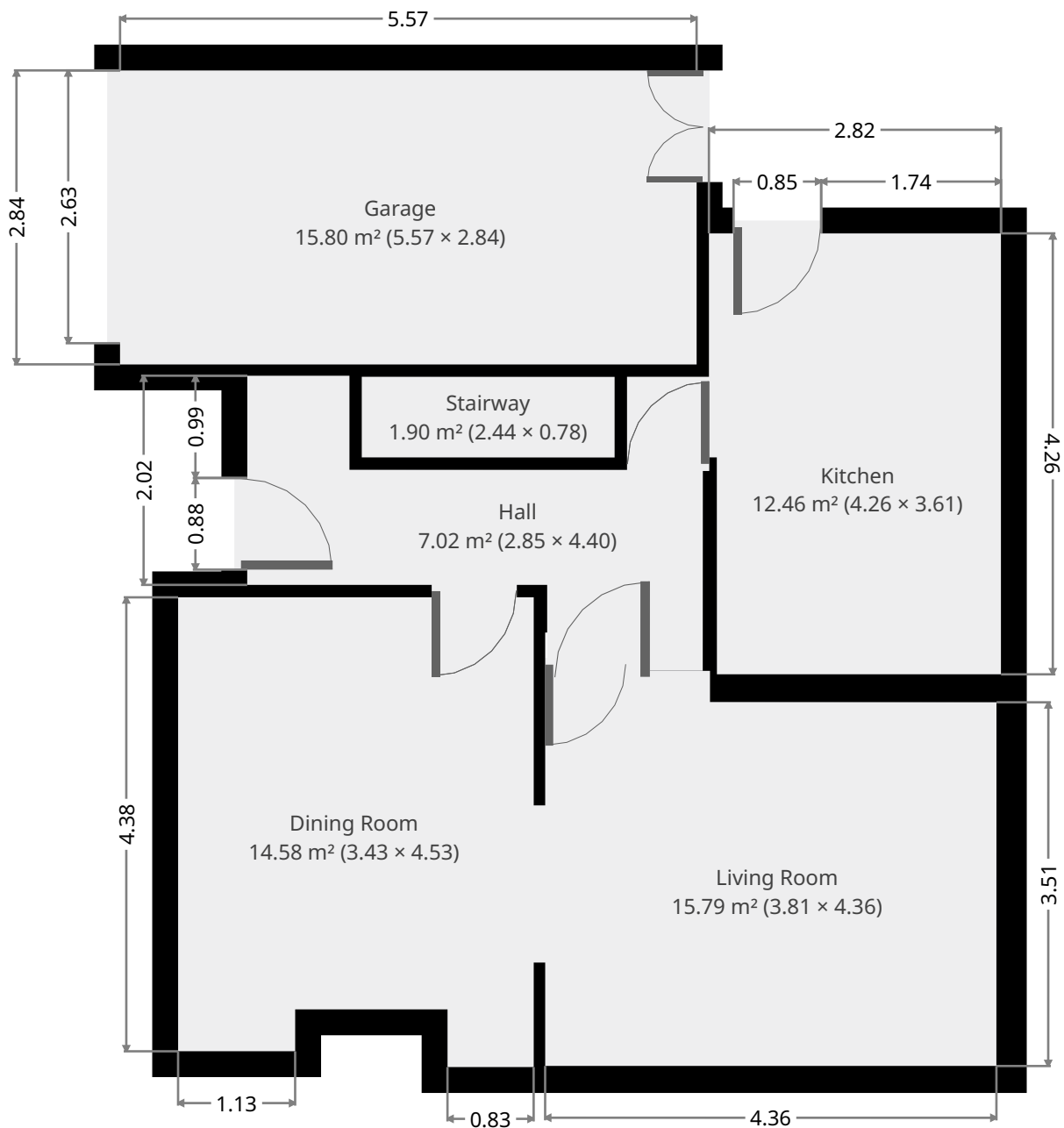

THIS FLOORPLAN IS PROVIDED WITHOUT WARRANTY OF ANY KIND. SENSOPIA DISCLAIMS ANY WARRANTY INCLUDING, WITHOUT LIMITATION, SATISFACTORY QUALITY OR ACCURACY OF DIMENSIONS.

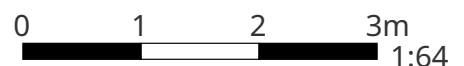



Dining Room

Width: 3.43 m
Length: 4.53 m
Area: 14.58 m²
Perimeter: 16.74 m

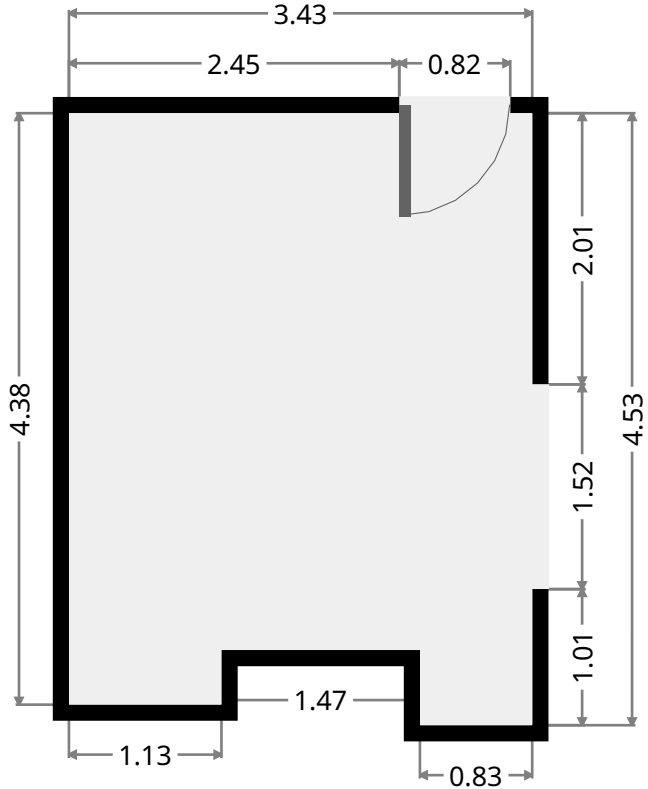
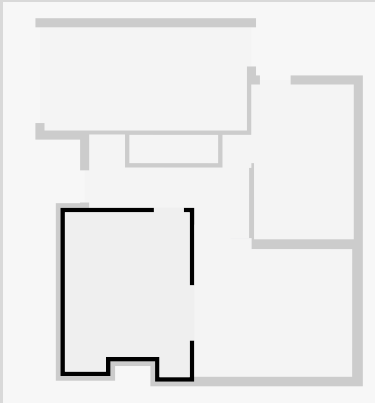

Living Room

Width: 3.81 m
Length: 4.36 m
Area: 15.79 m²
Perimeter: 16.34 m

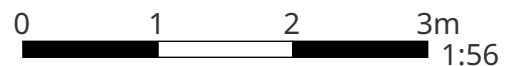
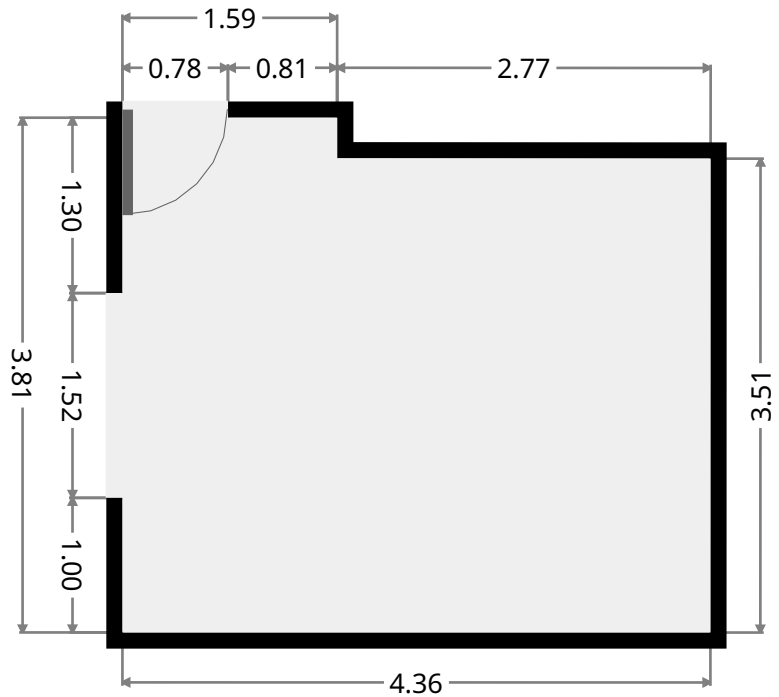
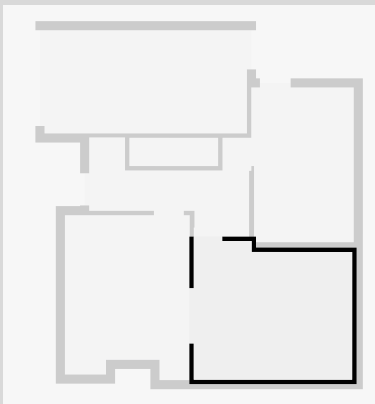

100 Roebuck road

Sean O'Donoghue
sean@bespoke.ie
+353 (87) 2630047



Hall

Width: 2.85 m
Length: 4.40 m
Area: 7.02 m²
Perimeter: 14.49 m

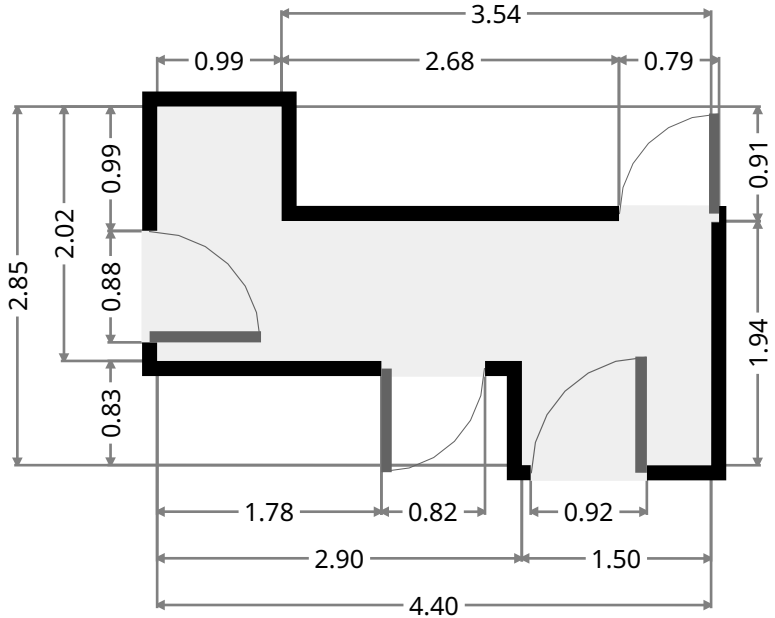
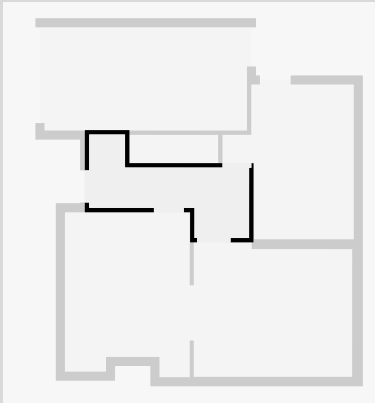

Kitchen

Width: 3.61 m
Length: 4.26 m
Area: 12.46 m²
Perimeter: 15.74 m

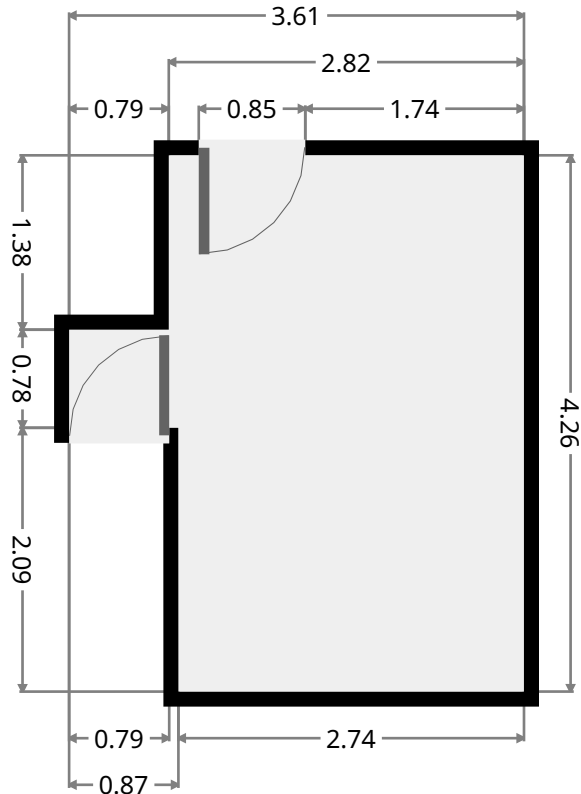
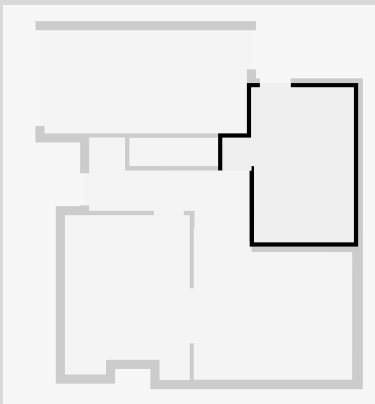

THIS FLOORPLAN IS PROVIDED WITHOUT WARRANTY OF ANY KIND. SENSOPIA DISCLAIMS ANY WARRANTY INCLUDING, WITHOUT LIMITATION, SATISFACTORY QUALITY OR ACCURACY OF DIMENSIONS.

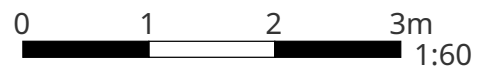



Garage

Width: 2.84 m
Length: 5.57 m
Area: 15.80 m²
Perimeter: 16.81 m

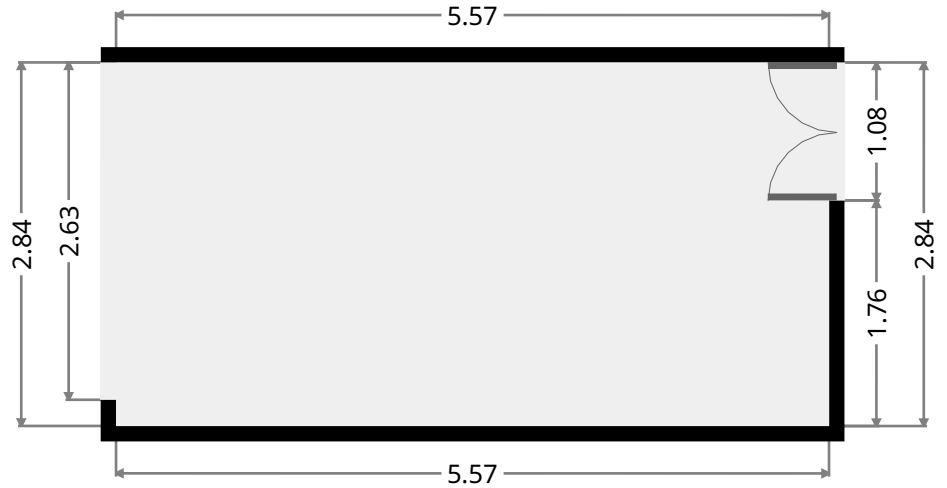
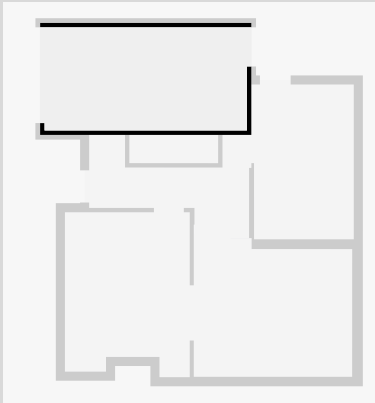

Stairway

Width: 0.78 m
Length: 2.44 m
Area: 1.90 m²
Perimeter: 6.44 m

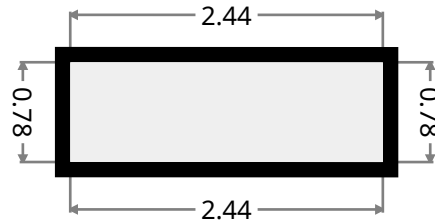
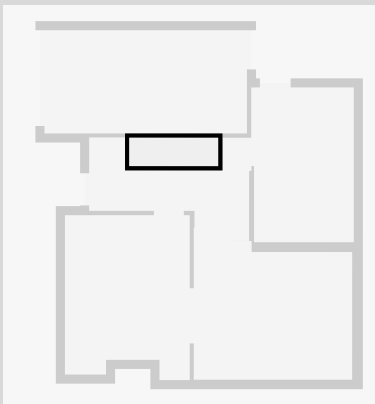

100 Roebuck road

Sean O'Donoghue
sean@bespoke.ie
+353 (87) 2630047



Statistics

Area: 99 m²
Living area: 121 m²
2 Floors
4 Bedrooms
1 Bathroom

1st Floor

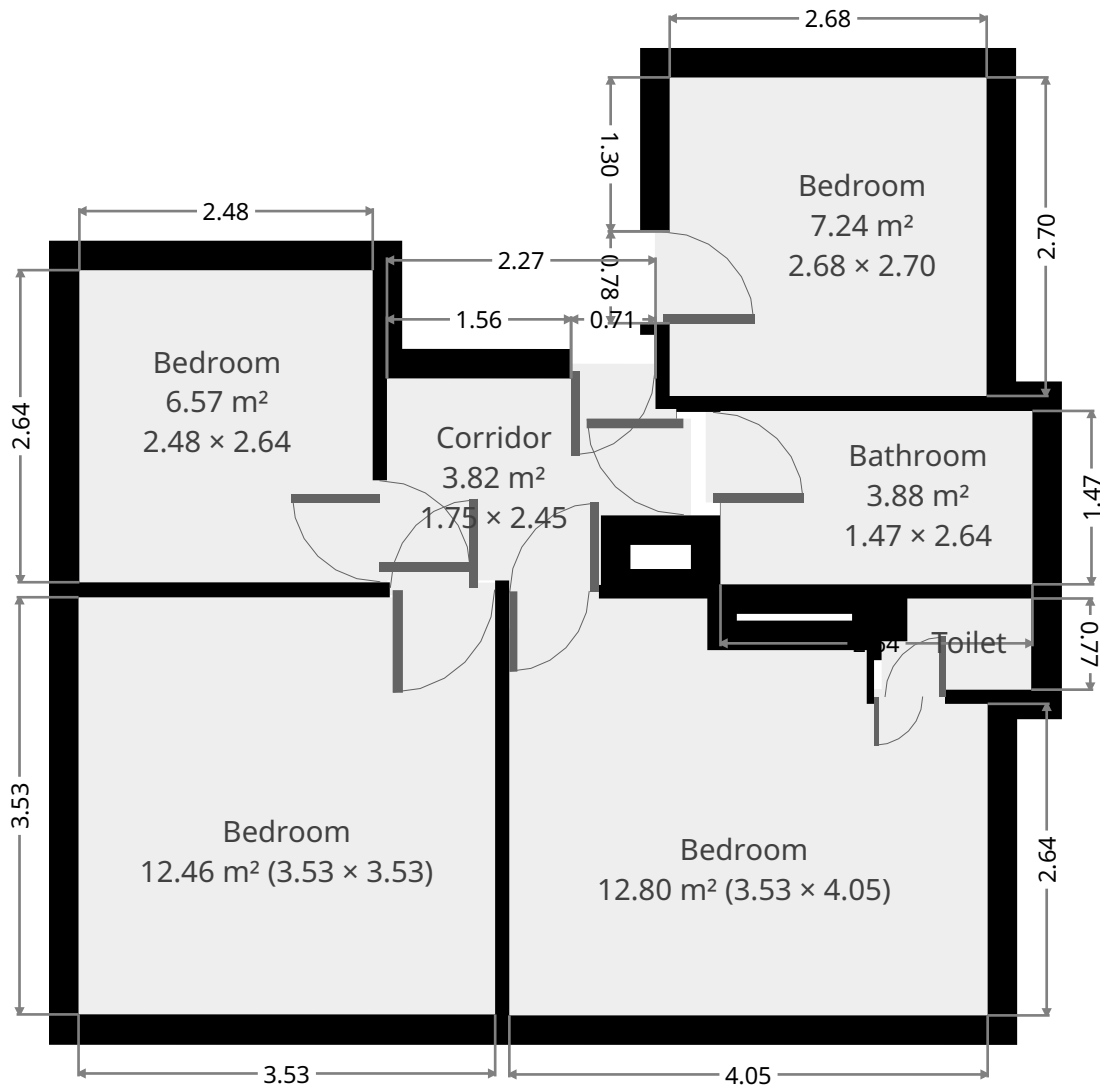

THIS FLOORPLAN IS PROVIDED WITHOUT WARRANTY OF ANY KIND. SENSOPIA DISCLAIMS ANY WARRANTY INCLUDING, WITHOUT LIMITATION, SATISFACTORY QUALITY OR ACCURACY OF DIMENSIONS.

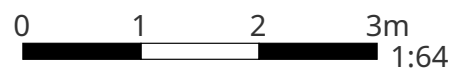



Bedroom

Width: 3.53 m
Length: 3.53 m
Area: 12.46 m²
Perimeter: 14.12 m

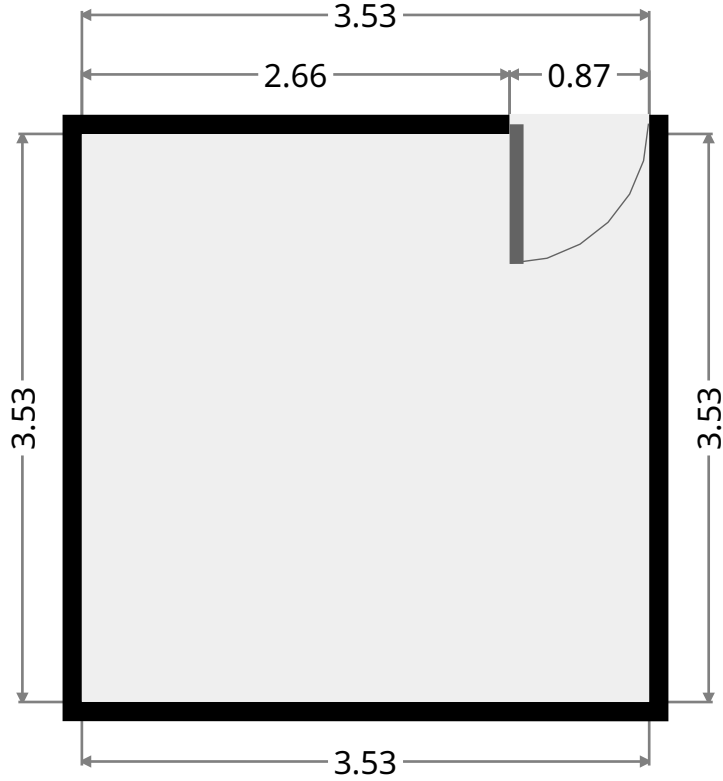
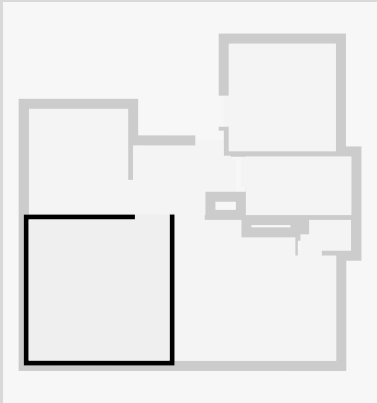

Bedroom

Width: 3.53 m
Length: 4.05 m
Area: 12.80 m²
Perimeter: 15.16 m

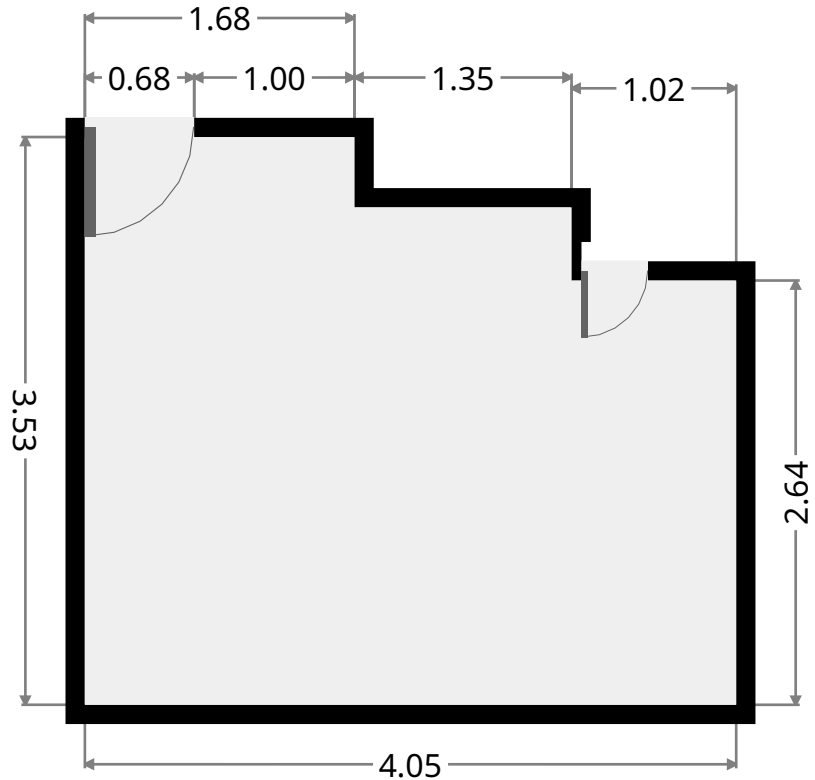
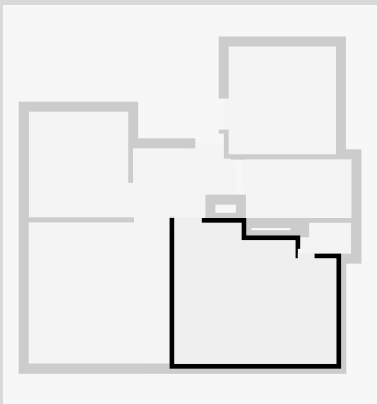



Bedroom

Width: 2.48 m
Length: 2.64 m
Area: 6.57 m²
Perimeter: 10.25 m

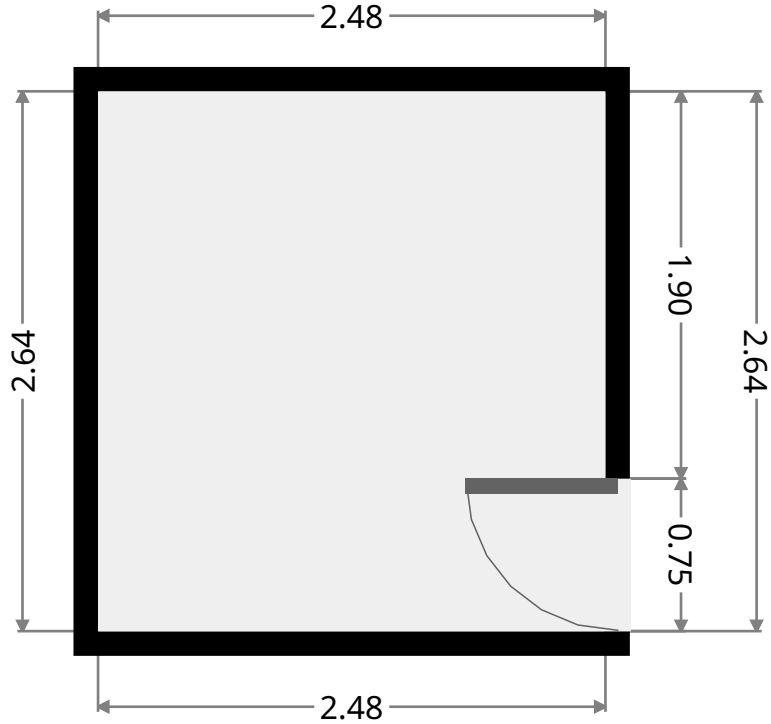
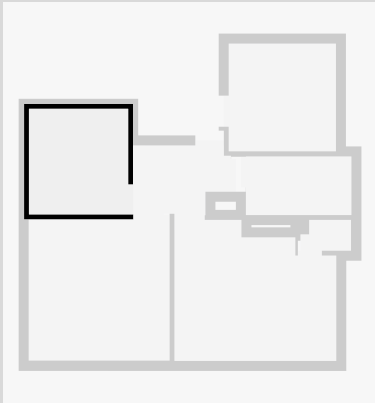

Bedroom

Width: 2.68 m
Length: 2.70 m
Area: 7.24 m²
Perimeter: 10.76 m

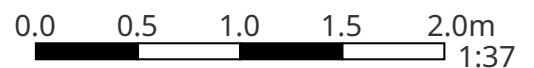
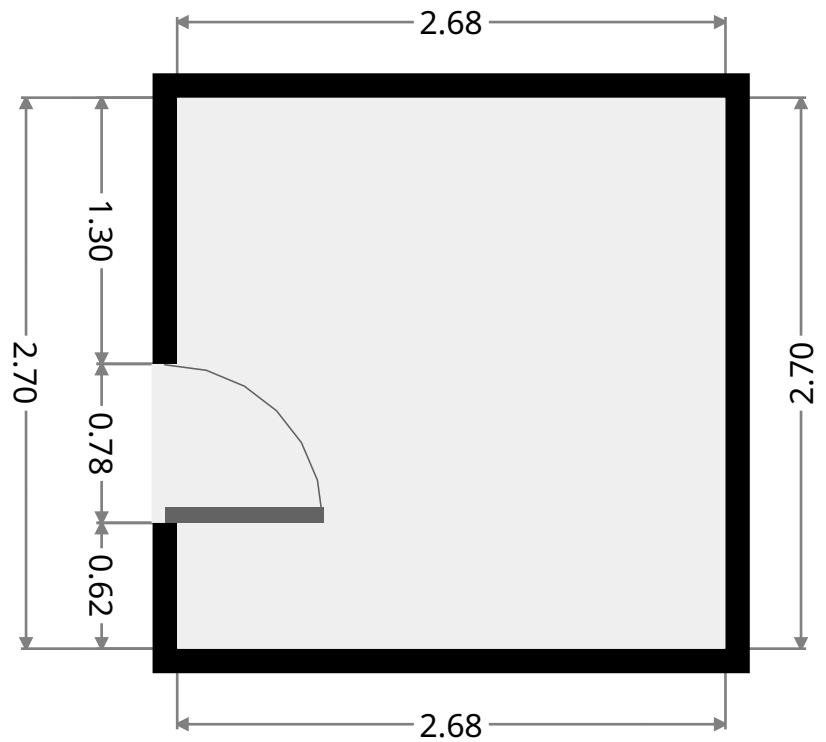
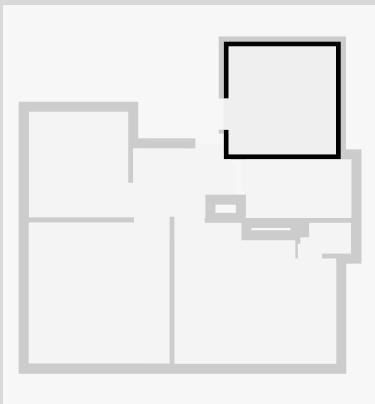



Bathroom

Width: 1.47 m
Length: 2.64 m
Area: 3.88 m²
Perimeter: 8.22 m

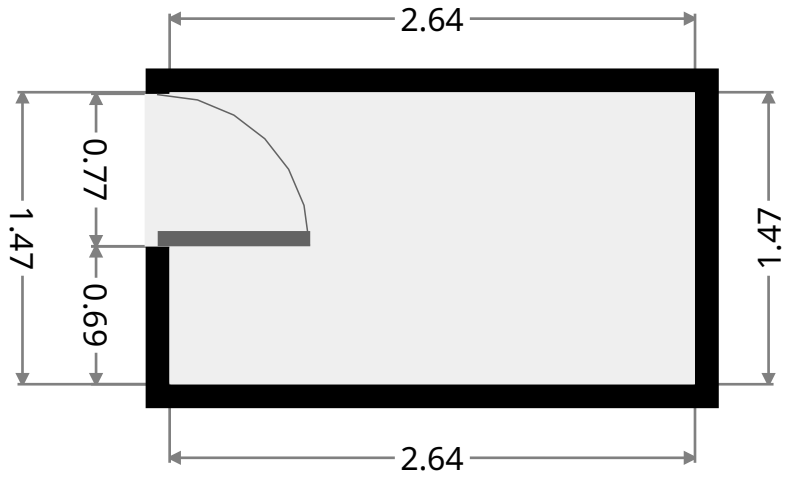
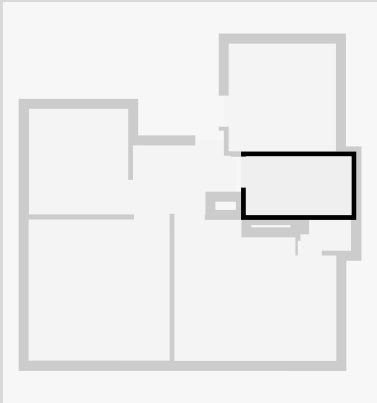

Corridor

Width: 1.75 m
Length: 2.45 m
Area: 3.82 m²
Perimeter: 8.40 m

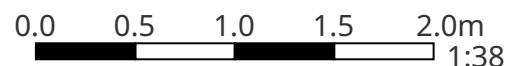
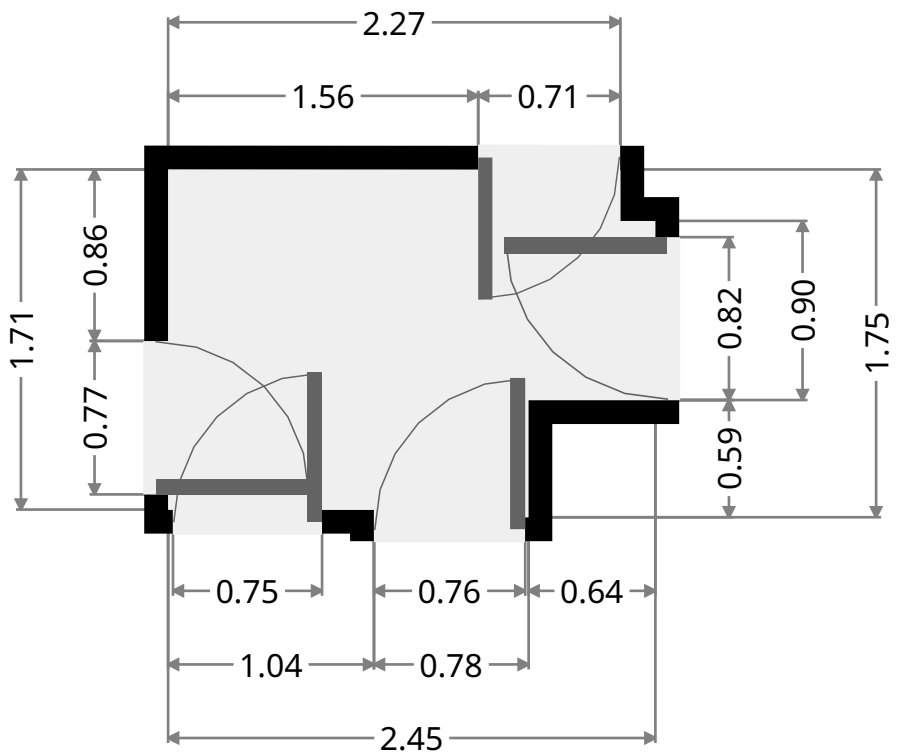
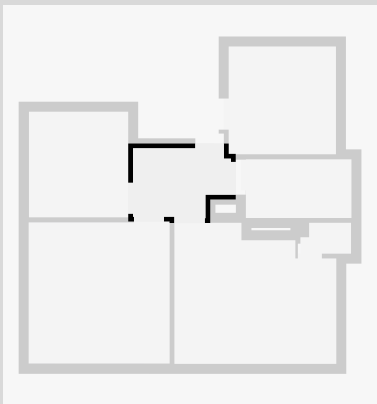



Toilet / Half Bath

Width: 0.77 m
Length: 1.27 m
Area: 0.90 m²
Perimeter: 4.08 m

